

# LuK Repair Solution for Dry Double Clutches

Removal and Installation  
Special Tool/Damage Diagnostics

Alfa Romeo, Fiat, Jeep, Suzuki C635 DDCT 6-speed transmission



The content of this brochure is not legally binding and is solely intended for information purposes. Where legally permissible, all liability on the part of Schaeffler Automotive Aftermarket GmbH & Co. KG devolving in connection with this brochure is excluded.

All rights reserved. Any reproduction, distribution, communication, public reproduction, or other publication of this brochure in its entirety or in part is not permitted without prior written consent from Schaeffler Automotive Aftermarket GmbH & Co. KG.

Copyright ©  
Schaeffler Automotive Aftermarket GmbH & Co. KG  
February 2021

## Schaeffler in the Automotive Aftermarket – more innovation, more quality and more service.



### Schaeffler REPERT – the service brand for garage professionals.

With REPERT, we offer a comprehensive service package for our products and repair solutions. Looking for specific information about damage diagnosis? Are you in need of particular tools to help make your every-day garage routine easier? Whether online portal, service hotline, installation instructions and videos, training seminars, or events – you get all technical services from a single source.

Register now for free, in just a few clicks, at: [www.repxpert.com](http://www.repxpert.com).

### Schaeffler in the Automotive Aftermarket – always the first choice for vehicle repair.

Whenever a vehicle needs to go to the garage, our products and repair solutions are first choice to fix them. With our system competence in transmission, engine, and chassis, we are a reliable partner around the world. Whether passenger cars, light and heavy commercial vehicles, or tractors – our optimally tuned components allow fast and professional parts replacement.

Our products are based on a comprehensive systems approach. Innovation, technical expertise, and the highest material and manufacturing quality make us not only one of the leading development partners for vehicle manufacturers, but also a pioneering provider of value-retaining spare parts and complete repair solutions for clutches and clutch release systems, engine and transmission applications, and chassis applications in original-equipment quality – right up to the appropriate special tools.

For over 50 years, we have offered everything needed for transmission repair under the LuK brand. Besides the LuK RepSet family and products for the entire hydraulic release system for professional clutch repair, the portfolio also includes the dual mass flywheel and components for expert repair of transmissions and differentials. It also includes professional solutions for transmission repair of commercial vehicles and tractors.

SCHAEFFLER  
**REPERT**





# Contents

	<b>Page</b>
<b>1 Diagnostics</b>	<b>6</b>
1.1 General information about the system	6
1.2 Emergency release	6
1.3 Wear test	7
1.4 Visual inspection	7
1.5 Noise	7
1.6 Troubleshooting with the diagnostic device	7
<b>2 Description and scope of delivery for the LuK RepSet 2CT</b>	<b>8</b>
<b>3 Description and scope of delivery for the LuK special tool</b>	<b>9</b>
<b>4 Removal and installation of the double clutch</b>	<b>10</b>
4.1 Repair instructions	11
4.2 Removal of the double clutch	12
4.3 Installation of the double clutch	18
<b>5 Instructions for the Dual Mass Flywheel (DMF)</b>	<b>27</b>
<b>6 DMF versions</b>	<b>28</b>
<b>7 DMF reset tool KL-0500-721</b>	<b>29</b>
<b>8 Resetting the anti-backlash ring of the DMF</b>	<b>31</b>
<b>9 Installation and initial operation</b>	<b>37</b>

# 1 Diagnose

## 1.1 General Information about the System

Before repairing the double clutch, some fundamental questions must be clarified with the customer in order to narrow down the error pattern as precisely as possible.

If the vehicle is still drivable, we recommend carrying out a test drive. The customer should be driving the vehicle whilst pointing out any problems.

### Specific Questions for the Customer:

- What exactly does not work or what are the symptoms?
- How long has the problem existed?
- Did the problem start suddenly or did it develop gradually (slowly)?
- How often does the problem occur: sporadically, often or always?
- In which driving condition does the problem occur: e.g. when starting, accelerating or decelerating, when the engine is cold or warm?
- What is the mileage of the vehicle?
- Is the vehicle subjected to extraordinary loads? E.g. towing a trailer, high load capacity, frequent hill climbs, operated as a taxi, fleet car, rental car, driving school?
- What is the driving profile: urban traffic, short journeys, intercity, highway?
- Have repairs already been carried out on the clutch/ transmission system?  
If so, at what mileage?  
What was the cause of that complaint?  
What repairs were carried out?

### Inspections on the Vehicle

At the beginning of removal work, it is recommended that the following points are checked:

- Defect code entries in the control unit (engine, transmission, clutch, comfort, CAN bus etc.)
- Battery power

### Warnings in the Event of System Malfunctions

A warning light in the instrument panel lights up in the event of malfunctions, operator errors or if the clutch overheats. In the event of serious errors, an acoustic signal sounds as well. Notes on the respective warnings are included in the vehicle handbook.

## 1.2 Emergency Release

### Manually Unlocking the Selector Lever (for example)

In the event of malfunctions in the electrical system or a discharged battery, the gear selector lever is blocked. To move the vehicle, the gear selector lever must be unlocked manually and moved out of the P position. To this end, a corresponding mechanism located under the shift lever sleeve must be operated.



The shift lever can be unlocked using a push button

### Manually Unlocking the Ignition Key (for example)

The key is blocked in the event of malfunctions or lack of power supply. The key cannot be removed from the lock. To remove the ignition key, insert a screwdriver into the dedicated opening of the steering column housing. Gently press to unlock the locking device.



The locking device for the ignition key can be overridden using a screwdriver

### 1.3 Wear Test

A wear test is not possible while the clutch is installed. The permanent monitoring system for the transmission and clutch electronics indicates wear-related errors directly in the instrument cluster.

### 1.4 Visual Inspection

Prior to each repair, the area of the clutch system must be checked for leaks and damage as a matter of course. Damage caused by parts that have broken off or oil leaks due to defective seals or sealing rings must be rectified before the clutch is replaced. If the clutch is oily, it must be replaced.

### 1.5 Noise

When assessing noises around the double clutch, perform a test drive to make sure that no noise is emanating from surrounding components, such as the emission system, heat shields, engine mountings, auxiliary equipment, etc. The radio, air conditioning and ventilation must be switched off during the noise investigation. A stethoscope can also be used in the garage, for example, to locate the source of the noise.

### 1.6 Troubleshooting with a Diagnostic Device

You can diagnose the transmission electronics and clutch electronics. Prior to each repair, the contents of the error memory must be read using a suitable diagnostic tool and, if possible, retained as a print-out. The error memory report provides an initial overview of the system errors and forms the basis for further repair measures. The report provides the data required to assess the error pattern (important when contacting the LuK INA FAG Service Center or in case of a warranty claim).

Once the double clutch has been replaced, a basic adjustment of the clutch system is required using the appropriate diagnostic tool, as well as an adjustment test drive of at least 20 km.

**Note:**

If you have any questions about diagnosis and repair, please contact our Technical Hotline on +44 (0)1432 264264.

Double Clutch: Gearbox Side



Double Clutch: Engine Side



## 2 Description and scope of delivery for the LuK RepSet 2CT

The LuK RepSet 2CT (Twin Clutch Technology) includes all the components required to replace the double clutch transmission. For a professional repair, it is recommended not only to replace the double clutch, but also all wear parts in the immediate vicinity.

Thanks to the LuK RepSet 2CT, Schaeffler Automotive Aftermarket is able to offer a complete and practical solution. The components included in the set are precision matched at the factory, eliminating problems caused by fitting a mix of incompatible components.



- |  |  |
|--|--|
| 1 Central engagement system                  | 6 Retaining element                          |
| 2 3 screws for the central engagement system | 7 Lip seal for the control rod               |
| 3 6 pressure plate screws                    | 8 Release bearing                            |
| 4 Double clutch                              | 9 4 screws for the concentric slave cylinder |
| 5 3 screws for the coupling flange           | 10 Concentric slave cylinder                 |



### 3 Description and scope of delivery for the LuK Special Tool

The tool kit (part no. 400 0471 10) contains all the tools required for the professional repair of dry double clutches in Alfa Romeos, Fiats, Jeeps and Suzukis (6-speed transmission C635 DDCT). The tool kit can be used without the basic tool kit. If the dual mass flywheel (DMF) is not replaced, the associated anti-backlash ring must be

reset and locked before installation of the transmission. This step is performed using the reset tool supplied. The tool can be adjusted to the respective DMF versions of the dry double clutch systems by Alfa Romeo and Fiat with just a few manual adjustments and can be used directly on the vehicle.



Article no 400 0471 10

- 1 2 plugs for differential openings
- 2 4 plugs for hydraulic openings
- 3 Installation device for the control rod
- 4 Hexagon socket set for the control rod
- 5 3 centering sleeves
- 6 3 threaded rods for centering sleeves
- 7 Installation device for the lip seal
- 8 Mounting sleeve for the lip seal
- 9 DMF reset tool
- 10 2 locking screws

**Note:**

If you have any questions in relation to the special tool, please contact our Technical Hotline on +44 (0)1432 264264.



REPAIRXPERT

ARBEITEN

LERNEN

INFORMIEREN

PRODUKT-KATALOG

TRAINING

AKTUELLES

REPARATUR-ANLEITUNG

DIAGNOSTIK

REPARATUR-ANLEITUNG

REPARATUR-ANLEITUNG

REPARATUR-ANLEITUNG

REPARATUR-ANLEITUNG

REPARATUR-ANLEITUNG

REPARATUR-ANLEITUNG

REPARATUR-ANLEITUNG

REPARATUR-ANLEITUNG

REPARATUR-ANLEITUNG

REPARATUR-ANLEITUNG

REPARATUR-ANLEITUNG

REPARATUR-ANLEITUNG

REPARATUR-ANLEITUNG

REPARATUR-ANLEITUNG

REPARATUR-ANLEITUNG

REPARATUR-ANLEITUNG

REPARATUR-ANLEITUNG

REPARATUR-ANLEITUNG

REPARATUR-ANLEITUNG

REPARATUR-ANLEITUNG

REPARATUR-ANLEITUNG

REPARATUR-ANLEITUNG

REPARATUR-ANLEITUNG

REPARATUR-ANLEITUNG

REPARATUR-ANLEITUNG

REPARATUR-ANLEITUNG

REPARATUR-ANLEITUNG

REPARATUR-ANLEITUNG

REPARATUR-ANLEITUNG

REPARATUR-ANLEITUNG

REPARATUR-ANLEITUNG

REPARATUR-ANLEITUNG

REPARATUR-ANLEITUNG

REPARATUR-ANLEITUNG

REPARATUR-ANLEITUNG

REPARATUR-ANLEITUNG

REPARATUR-ANLEITUNG

REPARATUR-ANLEITUNG

REPARATUR-ANLEITUNG

REPARATUR-ANLEITUNG

REPARATUR-ANLEITUNG

REPARATUR-ANLEITUNG

REPARATUR-ANLEITUNG

REPARATUR-ANLEITUNG

REPARATUR-ANLEITUNG

REPARATUR-ANLEITUNG

REPARATUR-ANLEITUNG

REPARATUR-ANLEITUNG

REPARATUR-ANLEITUNG

REPARATUR-ANLEITUNG

REPARATUR-ANLEITUNG

REPARATUR-ANLEITUNG

REPARATUR-ANLEITUNG

REPARATUR-ANLEITUNG

REPARATUR-ANLEITUNG

## 4 Removal and installation of the double clutch

### 4.1 Repair instructions

#### Valid for:

Alfa Romeo, Fiat, Jeep and Suzuki (6-speed transmission C 635 DDCT)

#### Using the LuK special tool:

part no. **400 0471 10**

#### Important Notes

##### for a Proper Repair:

- Repairs may be carried out only by specialist staff and using suitable garage equipment
- Due to on-going technical developments during volume production by the vehicle manufacturer, the repair process and the special tools required are subject to change
- Repairs must always be carried out using the latest repair instructions and the appropriate special tool

The latest data and information can be found at:

**[www.repxpert.com](http://www.repxpert.com)**

- If transmission oil or hydraulic oil leaks out during the repair, the oil level must be checked and if necessary refilled once the transmission is installed
- The dual mass flywheel (DMF) must be checked and if necessary replaced when the double clutch is replaced. In the process, particular attention must be paid to the internal gear teeth and the anti-backlash ring. The brochures entitled "The dry double clutch" and "Dual mass flywheel" contain more information about the DMF
- If the DMF is reused, the bracing ring must be reset using a special tool (e.g. LuK part no. **400 0471 10**) before installing the transmission. In the case of a new DMF, the anti-backlash ring is already reset

- Before installing the double clutch, the transmission input shafts must be cleaned thoroughly and checked for damage. The gearing must then be lubricated with a suitable lubricant. The vehicle manufacturer's instructions are to be observed as a priority. If no instructions regarding the lubricant are provided by the vehicle manufacturer, you can use a high-performance grease that is resistant to extreme temperatures and ageing (e.g. Castrol Olista Longtime 1 or 2)
- Clutch system components must not be greased or oiled (exceptions are clearly pointed out)
- After installing the clutch and transmission, a basic adjustment must be carried out using a suitable diagnostic system
- Oily and/or dirty transmission parts must be cleaned before using new components
- Cleanliness must be ensured throughout the entire repair process
- After the repair, an adjustment test drive of at least 20 km is recommended

#### Important:

Do not use DMF or double clutches that were dropped!

Do not clean components in a parts washing machine!

Do not remove the components (this can invalidate warranty claims)!

## 4.2 Removal of the double clutch

- Remove the transmission, observing the vehicle manufacturer's instructions
- After removing the drive shafts, insert the plugs (KL-0500-724) into the openings in the differential
- Place the gearbox in a position similar to the installation position on the vehicle

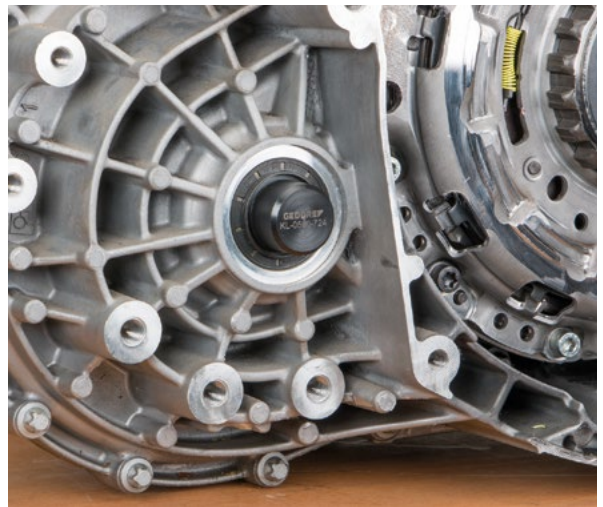

- Remove the release bearing retaining element

**Note:**

In the process, the retaining element is destroyed and must be replaced at the end of the repair (included in the LuK RepSet 2CT).



- Loosen the release bearing nut
- Remove the release bearing

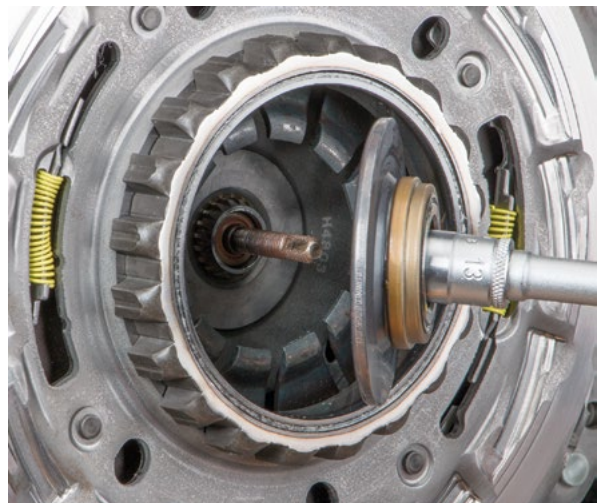

- Block the clutch (e.g. with a hexagon socket placed between the double clutch and bell housing)
- Remove six pressure plate screws (hexagonal socket)
- Remove the blocking tool

**Note:**

If the Torx screws are unscrewed, the clutch can no longer be used.

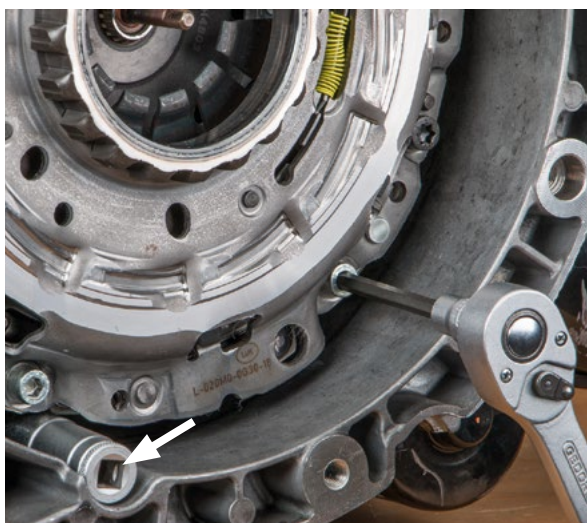

- Remove the clutch with the central plate from the transmission input shaft

**Important:**

Do not drop the clutch hub on the thread of the control rod!

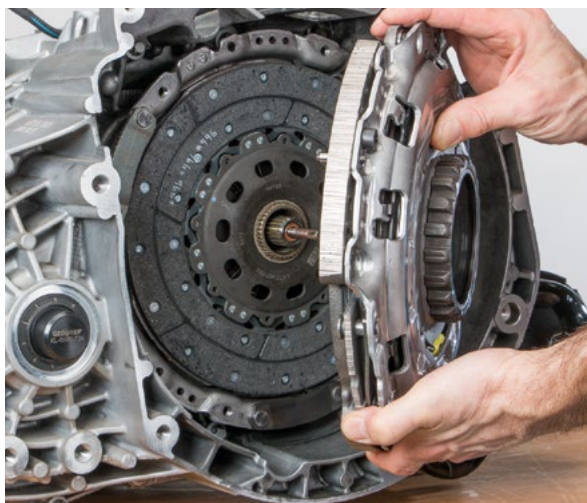

- Remove the clutch disc from the transmission input shaft



- Turn the pressure plate until all three screws of the flange bearing are accessible
- Remove the screws and the pressure plate

**Important:**

Do not drop the pressure plate on the thread of the control rod!



- Check the radial clearance of the control rod

**Note:**

The fit is virtually free of clearance. If the clearance is noticeable, the bush in the transmission input shaft or the control rod is worn (see page 17).

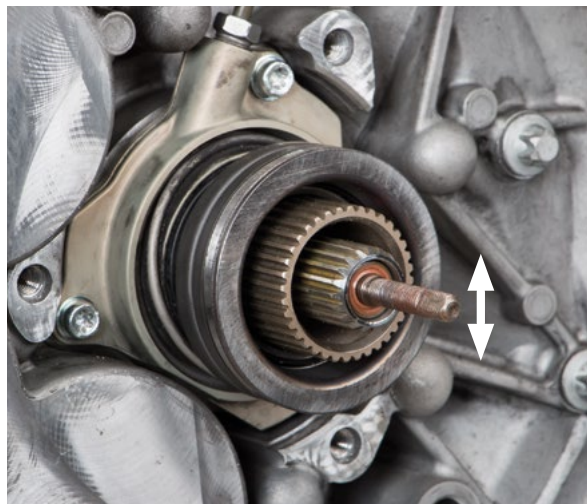

- Remove the three screws of the central engagement system

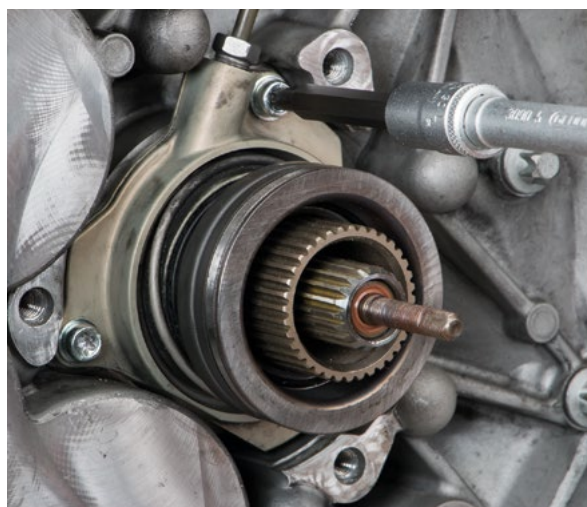

- Release the safety clips on the hydraulic pipe
- Remove the hydraulic pipe

**Important:**

Hydraulic fluid can escape with a low residual pressure.

Wear gloves and safety glasses!

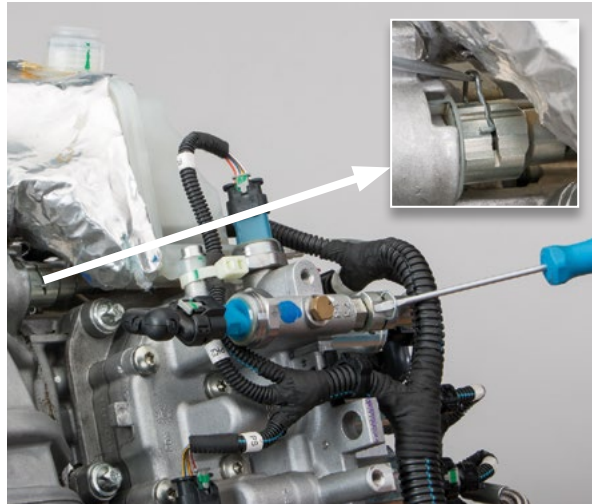

- Close the connection to the hydraulic unit with plug KL-0500-728

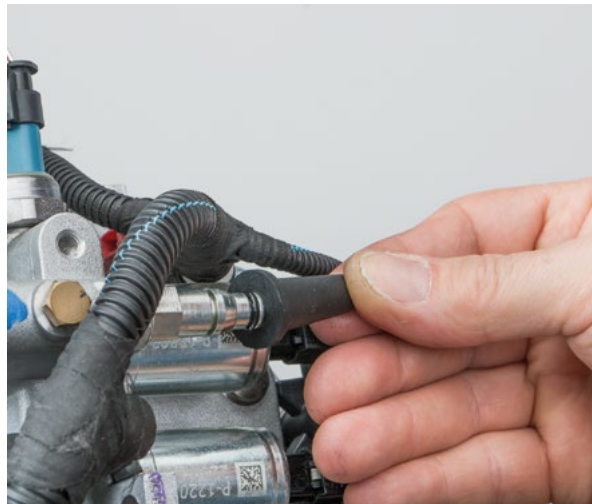

- Release both tabs of the plastic catch
- Remove the hydraulic connection from the catch
- Remove the central engagement system

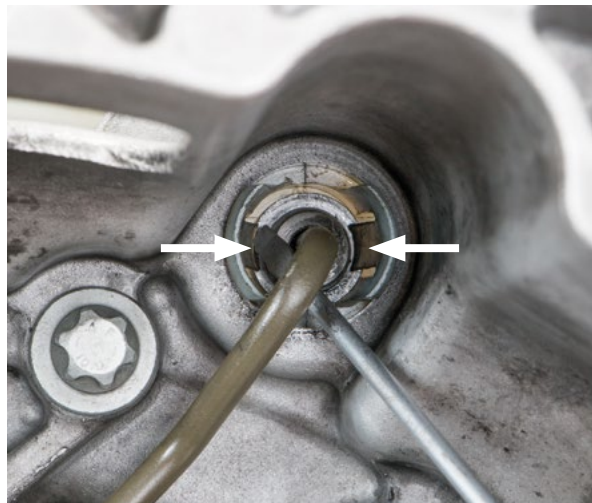

- Remove the safety clip from the hydraulic pipe
- Pull the hydraulic pipe out of the concentric slave cylinder
- Close the hydraulic pipe with plug KL-0500-728
- Disconnect the electrical connection from concentric slave cylinder
- Remove four screws

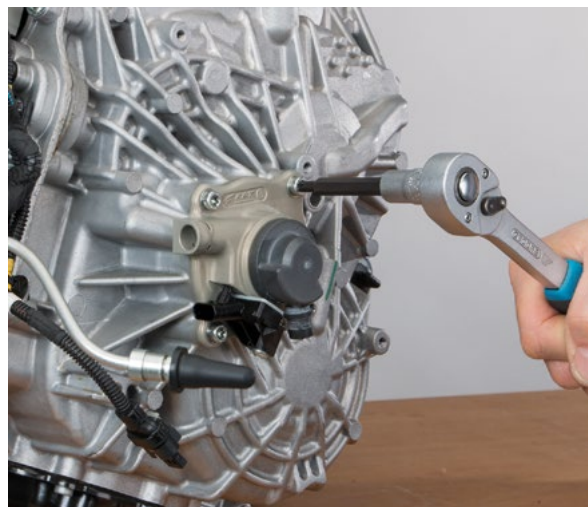

- Remove the concentric slave cylinder with the control rod
- Clean the sealing surface of the transmission housing

**Note:**

The oil deflector plate (1) is not part of the concentric slave cylinder. If it disengages during removal, reinstall it in the gearbox.



- Clamp special tool KL-0500-722 in a vice
- Insert the concentric slave cylinder into the special tool
- Remove the control rod with special tool KL-0500-726

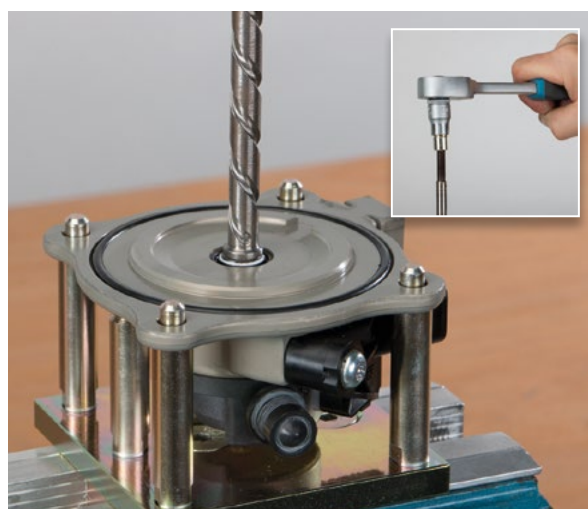



- Check the control rod for wear in the area of the bearings and the lip seal

**Important:**

If there is noticeable scoring or scratches in the area of the guide, the control rod must be replaced along with the bush in the transmission input shaft. This work step can be combined with the replacement of the lip seal (see below).



- Check the lip seals of the inner and outer transmission input shaft for leaks and, if necessary, replace according to the instructions of the vehicle manufacturer
- Clean the gearing of both transmission input shafts and check for damage

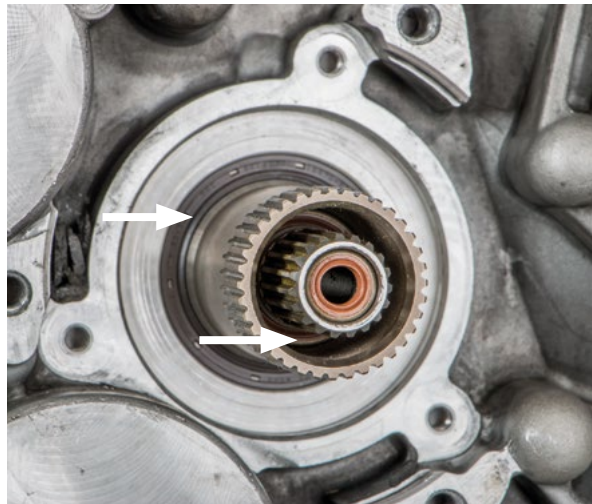

Remove the lip seal of the control rod

**Note:**

The seat of the lip seal must not be damaged during removal as this can lead to a loss of oil.

- If impermissible radial clearance is detected during the inspection of the control rod (see page 14), the guide bush can be replaced during this work step (note the specifications of the vehicle manufacturer)

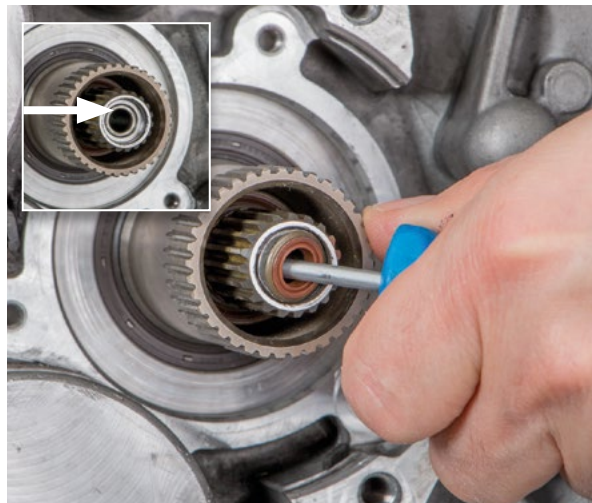

### 4.3 Installation of the double clutch

- Clean the thread of the control rod then apply thread-locking compound
- New control rods are already provided with Loctite



- Insert the new concentric slave cylinder into special tool KL-0500-722
- Screw the control rod into the concentric slave cylinder using special tool KL-0500-726 and secure with **8 Nm**

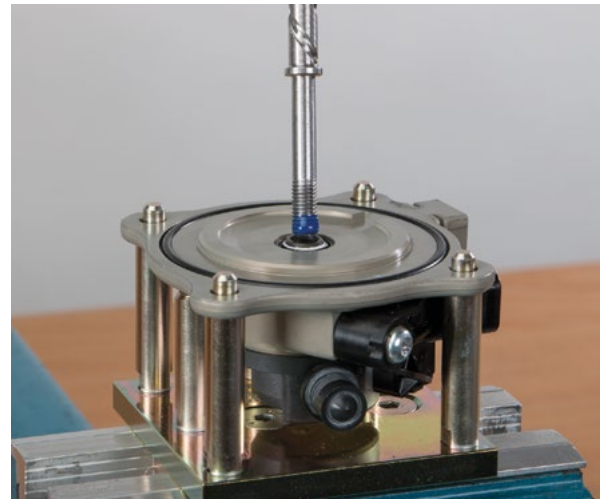

- Lay the clutch disc down on a clean surface. Make sure not to touch the friction surfaces with your bare hands; use gloves if necessary
- Coat the gearing of the clutch disc hub for the external transmission input shaft with a little lubricant

**Note:**

Take the vehicle manufacturer's specifications into account when choosing the lubricant. Unless specified, use a temperature and ageing-resistant, high-performance grease (e.g. Castrol Olista Longtime 2 or 3).



- Move the clutch disc back and forth several times in three different angular positions to the transmission input shaft over the full length of the splines



- Remove any excess lubricant from the outside of the splines of the clutch disc and the transmission input shaft



- Coat the splines of the inner input shaft with a thin layer of grease

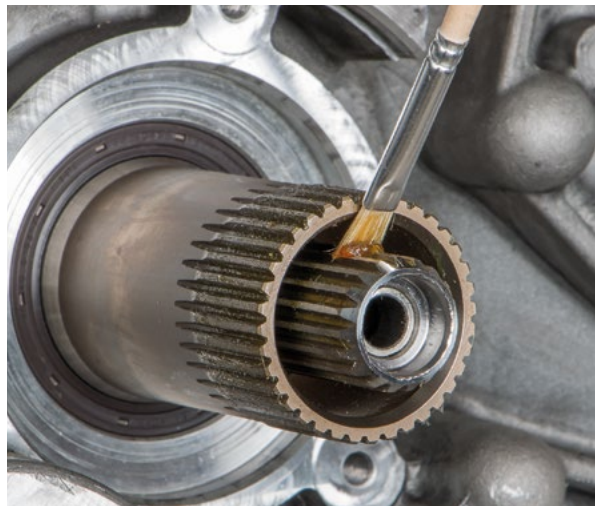

- Install the concentric slave cylinder with the control rod
- Make sure that the oil deflector plate is in the installation position
- Use a torque wrench to tighten the screws to **10 Nm ( $\pm 2$  Nm)**
- Remove the plug from the hydraulic pipe
- Connect the electrical and hydraulic connection to the concentric slave cylinder

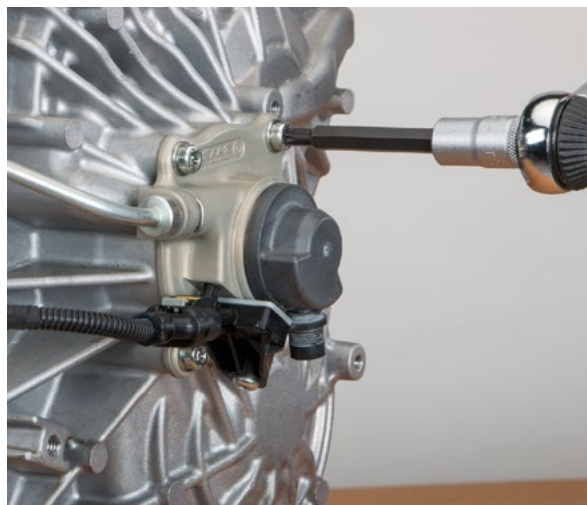

- Turn installation device KL-0500-723 on the thread of the control rod and then wet with gear oil
- Guide the lip seal up to the end of the installation device by hand, observing the installation direction

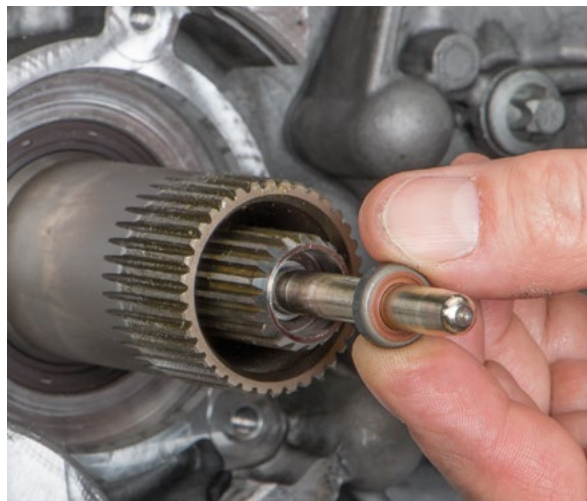

- Drive the lip seal to the specified end position with special tool KL-0500-725
- Remove the installation device

**Note:**

The mounting depth of the lip seal is limited by a transition in the transmission input shaft.

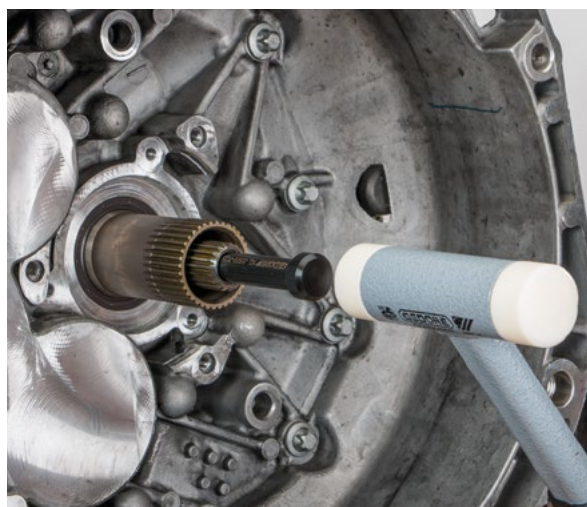

- Install the central engagement system
- Snap the hydraulic connection of the central engagement system into place in the plastic catch
- Tighten three new screws evenly by hand; do not tilt the concentric slave cylinder in the process
- Tighten the screws to **10 Nm ( $\pm 2$  Nm)**

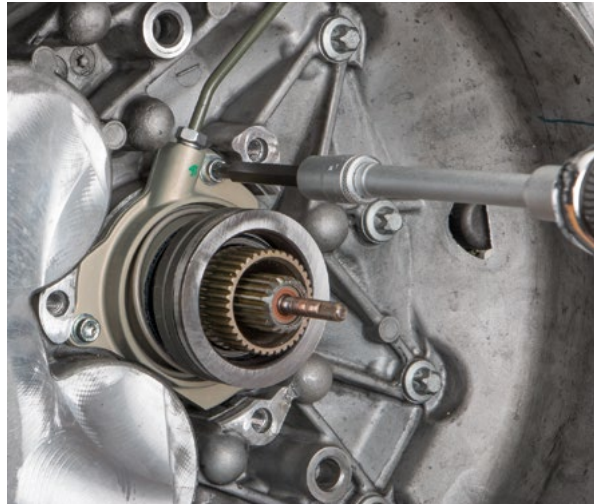

- First, attach the hydraulic pipe to the connection of the central engagement system and lock it with a safety clip
- Then remove the plug from the hydraulic unit and connect the pipe

**Note:**

When installing the hydraulic pipe, make sure that the connections are properly locked. Corrections on installed transmissions are extremely difficult due to space restrictions.



- Screw in threaded rods KL-0500-7271 as deep as possible by hand into the bell housing

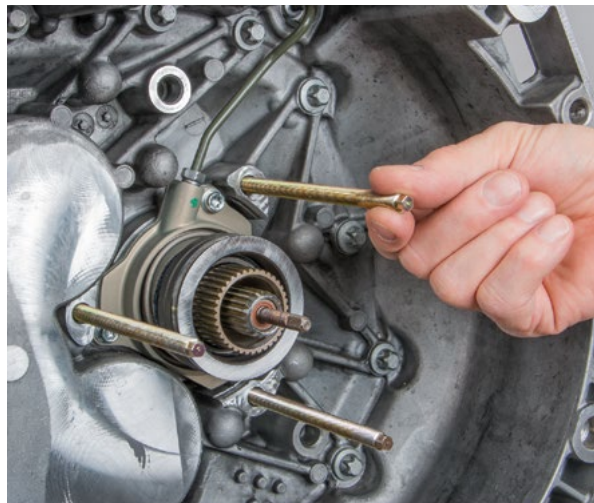

- Position the holes of the pressure plate and the flange above one another



- Guide the pressure plate with flange over the threaded rods of the special tool

**Important:**

When installing the pressure plate, the rounded recess of the flange (1) must be above the hydraulic connection of the concentric slave cylinder (2) once the hydraulic connection is assembled.

If the flange is incorrectly installed, the clutch and engaging system will be damaged!



- Screw three centering sleeves KL-0500-727 evenly onto the threaded rods by hand; do not tilt the flange in the process

**Note:**

During this work step, the flange of the clutch is pressed against preload of the central engagement system in the seating of the transmission. In the process, the increased force required for turning does not yet indicate the final installation position. The clutch only reaches its correct installation position when all sleeves have come to a stop and the threaded rods have the same length.



- Remove the first threaded rod with the sleeve, replace with a new screw and tighten by hand
- Repeat the work step with the second and third threaded rods
- Tighten the three screws with **25 Nm (±10%)**
- Check that the pressure plate can be turned by hand evenly and silently
- Degrease the friction surface of the pressure plate

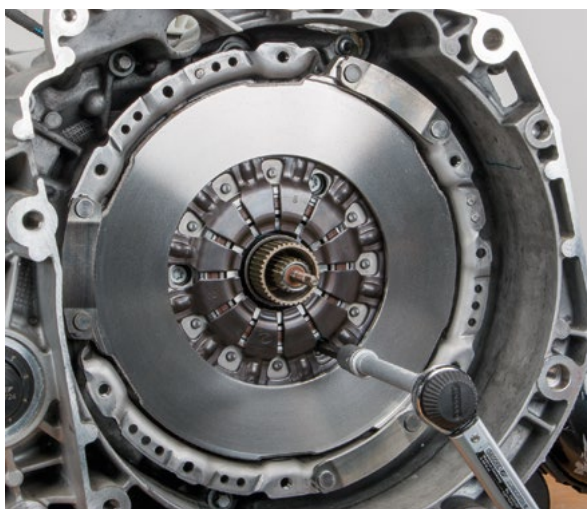

- Install the clutch disc

**Note:**

Note the installation position. The labels “FLYWHEEL SIDE” or “LATO MOTORE” must be facing the flywheel.

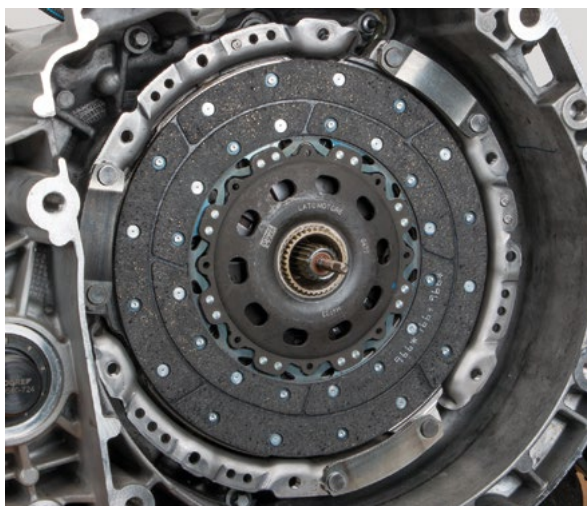

- Set the notch of the clutch to the “11 o’clock” position

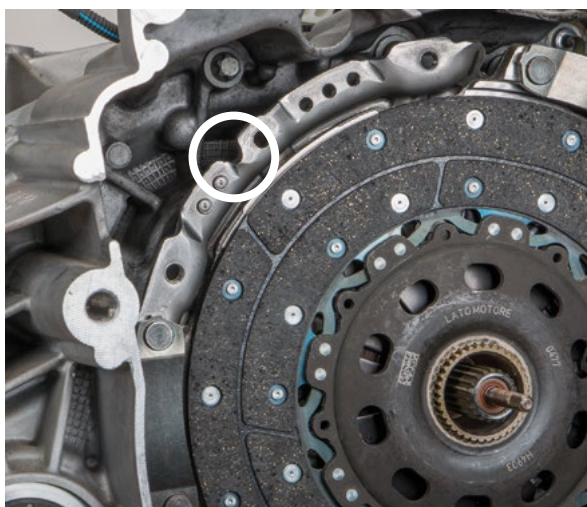

- Degrease the friction surface of the central plate
- Install clutch with central plate. Make sure that the clutch hub does not interfere with or damage the thread of the control rod

**Important:**

During installation, the notches of the clutches and the central plate must be aligned!



- Hand tighten the screws
- Evenly and sequentially tighten to **25 Nm ( $\pm 10\%$ )** (if necessary, block clutch in same way as removal)

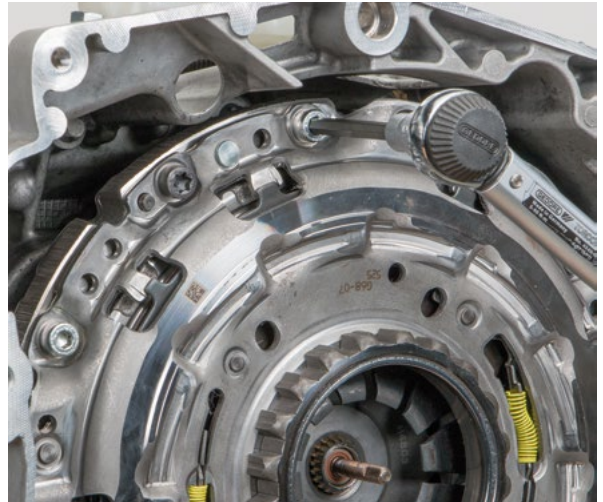

- Screw on the release bearing until there is contact with the diaphragm spring, then carefully continue to turn until the thrust washer remains stationary

**Important:**

The nut should no longer be screwed in with the thrust washer stationary, as this negatively affects the measuring result of the following test.





- Place the steel ruler on both sides of the bell housing
- Measure the distance to the control rod and note as measured value 1

**Example: Measured value 1 = 21.0 mm**

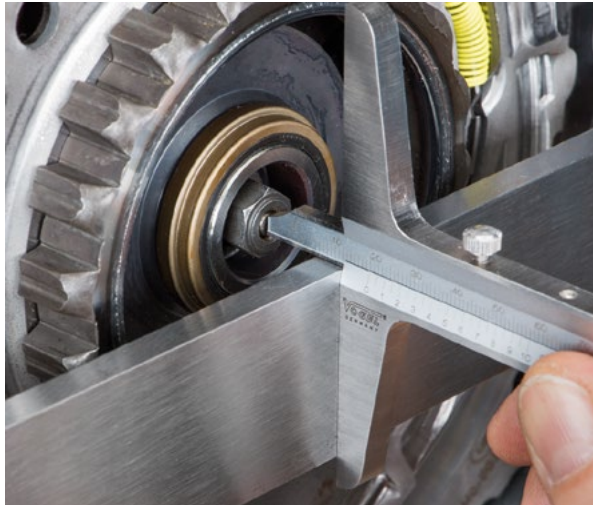

- Measure the distance to the plate of the release bearing and note as measured value 2

**Example: Measured value 2 = 35.0 mm**

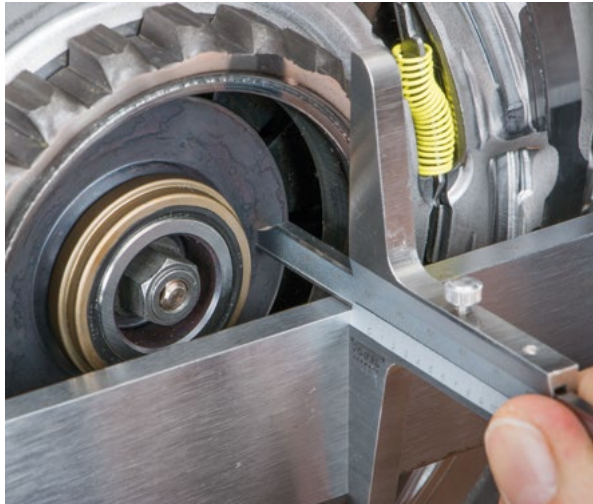

- Turn in the release bearing by 10.5 revolutions



- Determine the distance to the control rod again
- Subtract the measured value from measured value 1

**Example: 21.0 mm – 10.5 mm = 10.5 mm**

- The calculated value must equal **10.5 mm (±0.1 mm)**
- If a value is outside the tolerance range, adjust the release bearing nut until the required value is reached

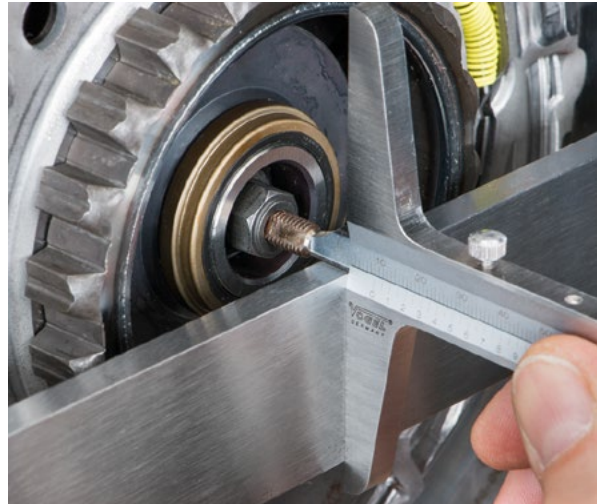

- Determine the distance to the plate of the release bearing again
- Compare the determined measurement with measured value 2

**Example:**                    **35.0 mm (measured value 2)**  
                                      **35.0 mm (determined dimension)**  
deviation:                    **0.0 mm**

- Deviations of more than ±2 mm are inadmissible and indicate an error in installing the thrust bearing or in its basic adjustment. To correct this, it is recommended to repeat these work steps

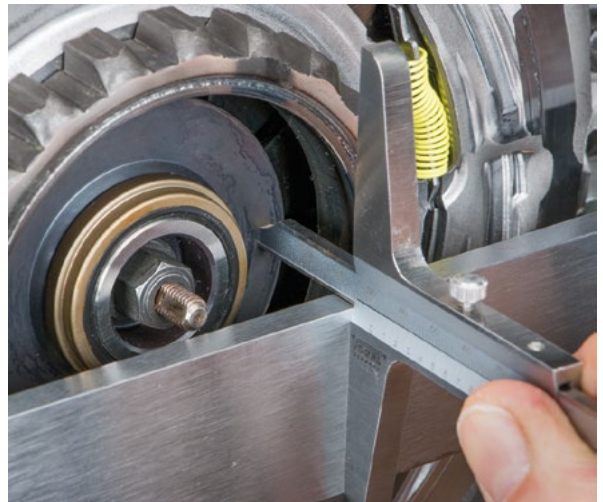

- Install the new screw-locking device



## 5 Instructions for the Dual Mass Flywheel (DMF)

### Important:

Before installing the transmission, the bracing ring of a previously used DMF must be reset. If this is not observed, the double clutch and the DMF will be damaged!

- A function test on the DMF is not possible using garage equipment. If broken-off spring tabs or retaining lugs are detected during the visual inspection, the DMF must be replaced

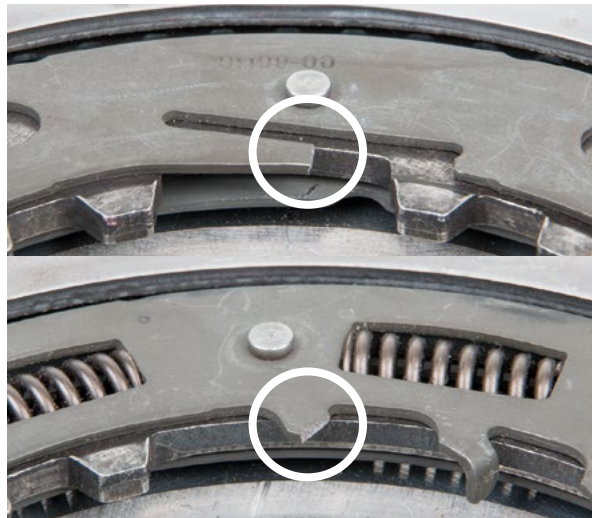

### DMF with a Reset Anti-backlash Ring

- The coil springs of the anti-backlash ring are compressed and the spring tabs are at the stop
- The transmission can be mounted

### Note:

New DMFs are always delivered with a reset anti-backlash ring.

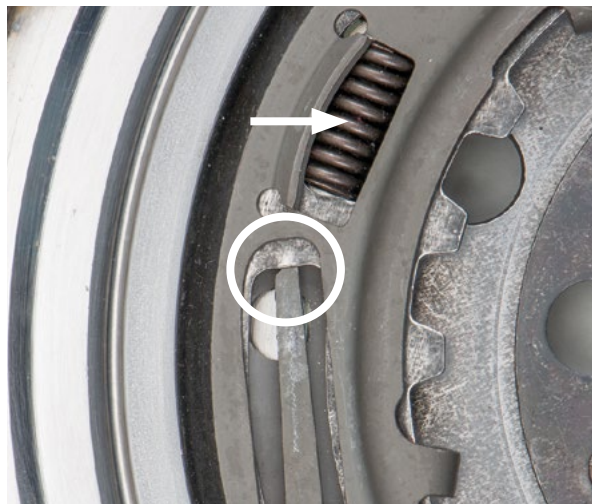

### DMF with Triggered Anti-backlash Ring

- In the case of a previously used DMF, the coil springs of the anti-backlash ring are relaxed and the spring tabs are above the stop
- The transmission must not be mounted yet
- Before installing the transmission, the anti-backlash ring must be reset using a special tool, e.g. KL-0500-721

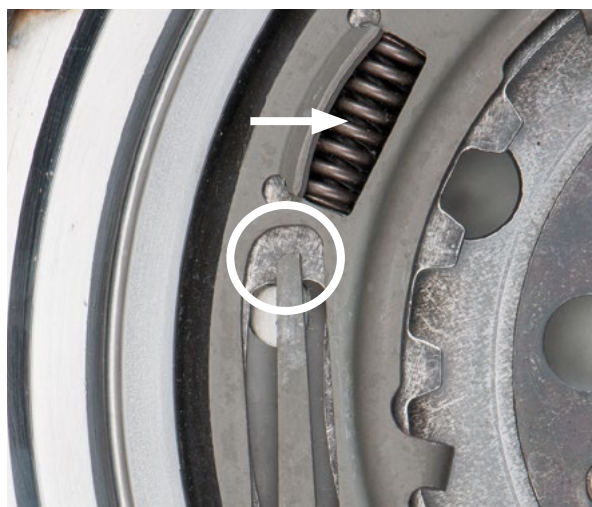

## 6 DMF versions

Petrol and diesel engines can be equipped with two different DMF versions. The more current versions can be identified by the anti-backlash ring with a flap for pivoting coil spring. In the case of older vehicles, this design feature is missing.

In the following repair procedure, each DMF is assigned a particular mounting position on the reset tool. It is therefore advisable to use the images below to determine the DMF installed in the vehicle and to note down the version number.

### DMF for Diesel Engines

Version 1: Anti-backlash ring with flap for pivoting coil spring



Version 3: Anti-backlash ring without flap for pivoting coil spring



### DMF for Petrol Engines

Version 2: Anti-backlash ring with flap for pivoting coil spring

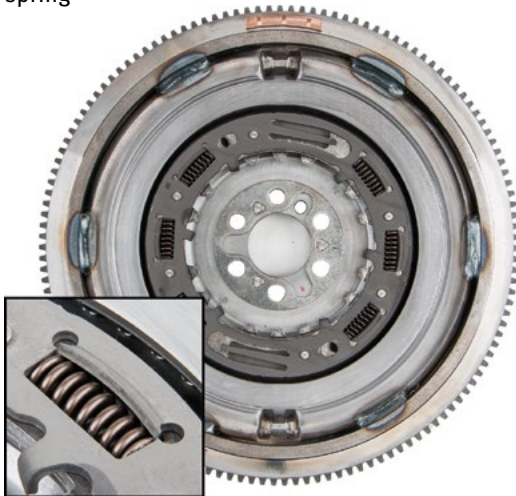

Version 4: Anti-backlash ring without flap for pivoting coil spring



## 7 DMF reset tool KL-0500-721

### Design

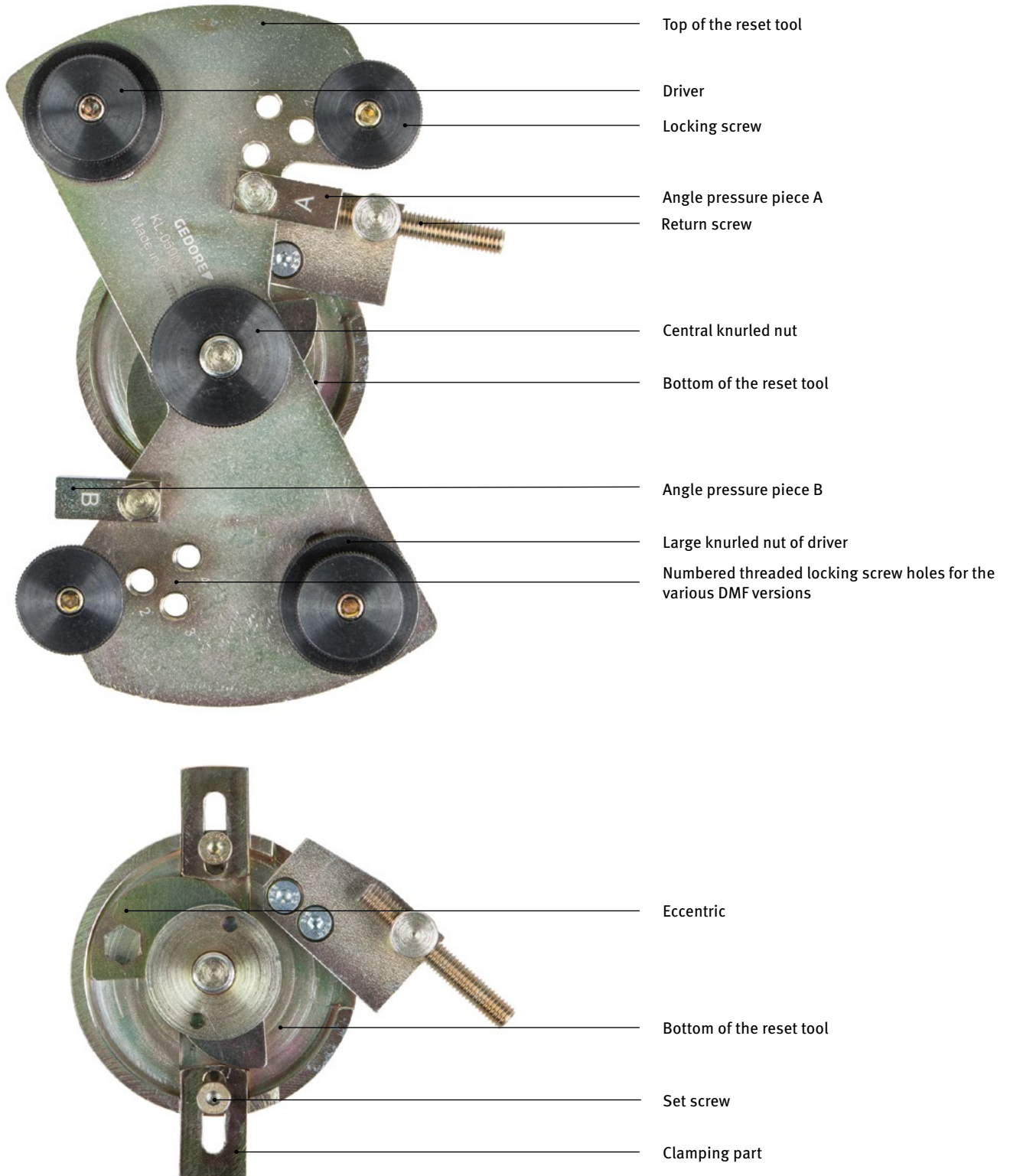

## Description

Vehicles with a dry double clutch are equipped with a special design of the DMF. Instead of the friction surface, a flange with internal gearing is used. The toothed gear of the double clutch meshes with this flange. Since the two interlocking gear rings would otherwise produce noise, an anti-backlash ring is attached to prevent noise. This anti-backlash ring tensions the two sprockets so that the tooth flanks have no clearance between them.

If the mounted DMF is to be reused in an Alfa Romeo, Fiat, Jeep and Suzuki dry double clutch system, the anti-backlash ring must be reset before the transmission is installed.

The reset tool KL-0500-721 can be used to reset the anti-backlash rings of all DMFs on the market up to now for Alfa Romeo, Fiat, Jeep and Suzuki vehicles with a dry double clutch. The DMF does not need to be removed.

## Application Example

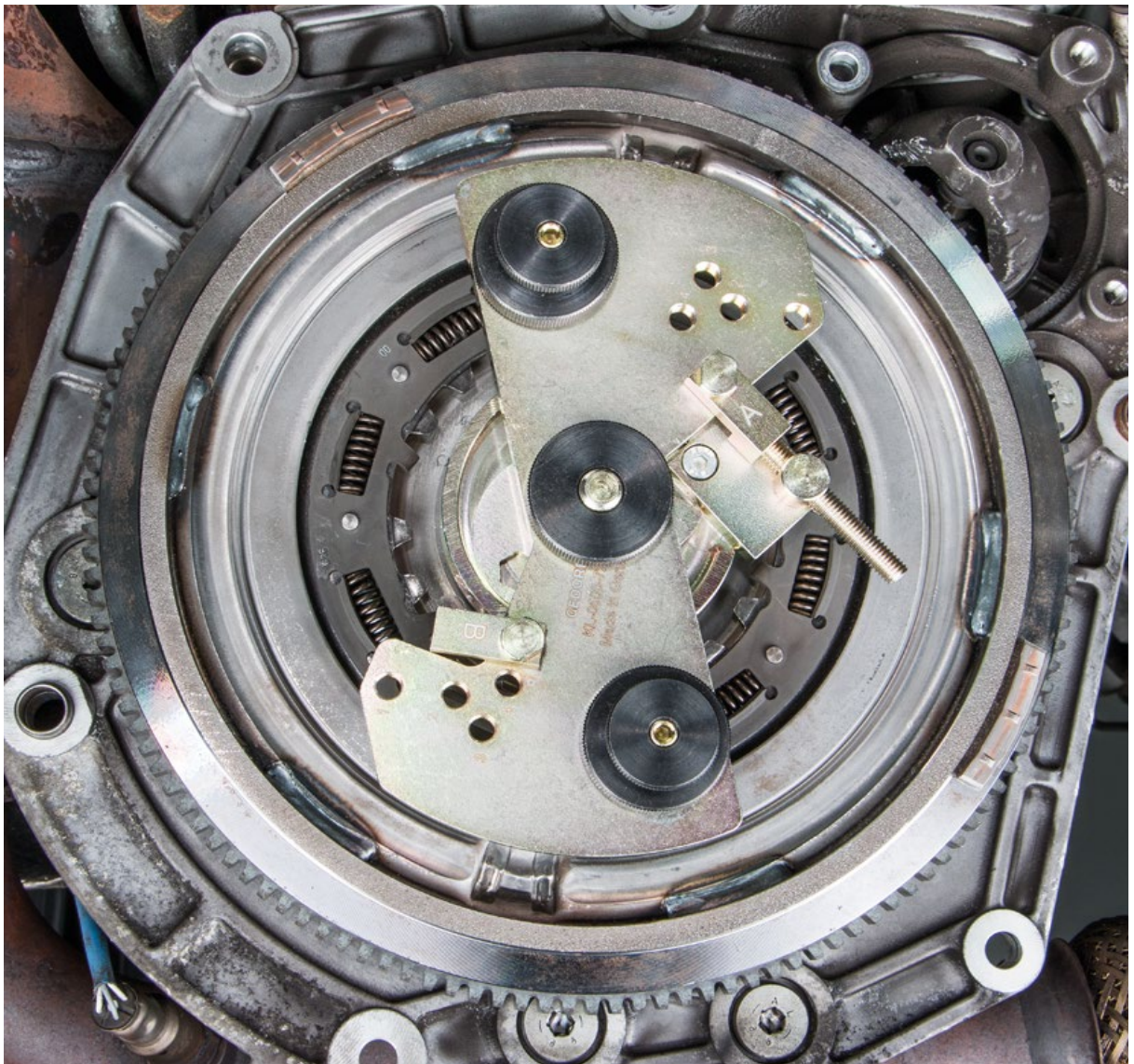

## 8 Resetting the anti-backlash ring of the DMF

Mounting position of the bottom of the reset tool for the respective DMF versions.

### Version 1

Diesel engine  
Anti-backlash ring with flap for pivoting coil spring



### Version 2

Petrol engine  
Anti-backlash ring with flap for pivoting coil spring

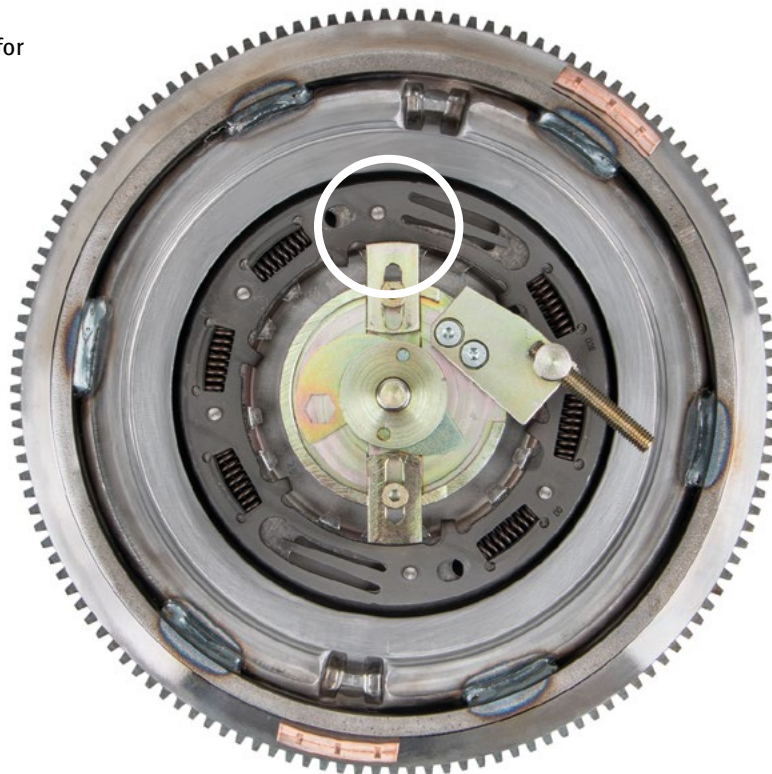

### Version 3

Diesel engine  
Anti-backlash ring without flap for  
pivoting coil spring



### Version 4

Petrol engine  
Anti-backlash ring without flap for  
pivoting coil spring





**Note:**

The following instruction shows an example of resetting version 1. All other versions can be reset according to the same principle.

- Place the bottom of the reset tool centrally on the DMF (observe the installation position of the respective version; see pages 31 and 32)
- Turn the eccentric clockwise using an Allen key until both clamps fit in the teeth of the DMF
- Hold the eccentric with a small preload
- Check that the clamps are correctly seated in the teeth

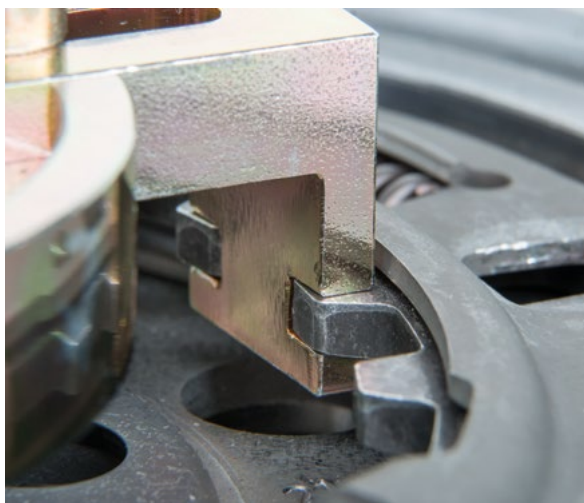

- Tighten both set screws
- Unscrew the reset screw with hexagonal socket as far as possible



- Turn driver (1) back to the stop
- Mount the top of the reset tool without locking screws
- Secure central knurled nut by hand

**Note:**

In DMF versions 1 and 4, angle pressure piece **B** of the top of the reset tool points toward the reset screw. For versions 2 and 3, the top must be mounted in such a way that the angle pressure piece **A** points toward the reset screw.

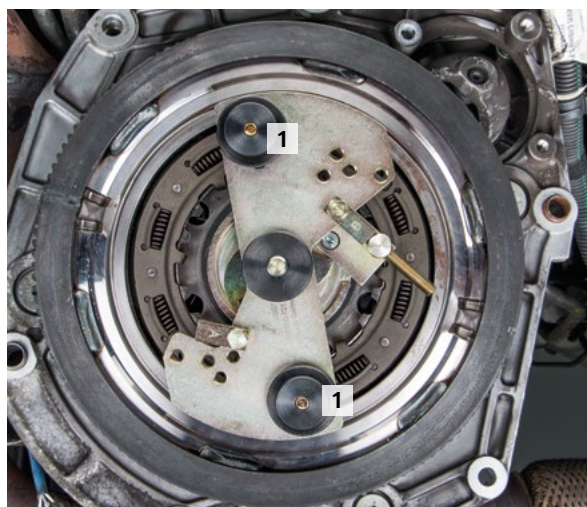

- Align the drivers over the holes in the anti-backlash ring and screw in evenly until the discs are on the holes of the anti-backlash ring
- Tighten the large knurled nuts of the drivers by hand

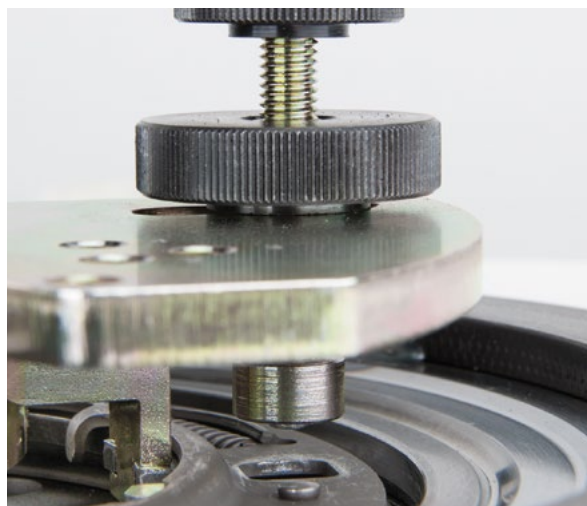

- Evenly preload both drivers slightly

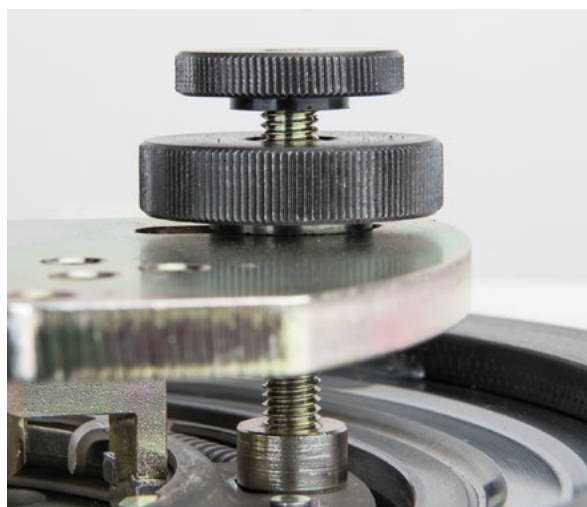

- Screw in the reset screw so that the anti-backlash ring twists against the spring force

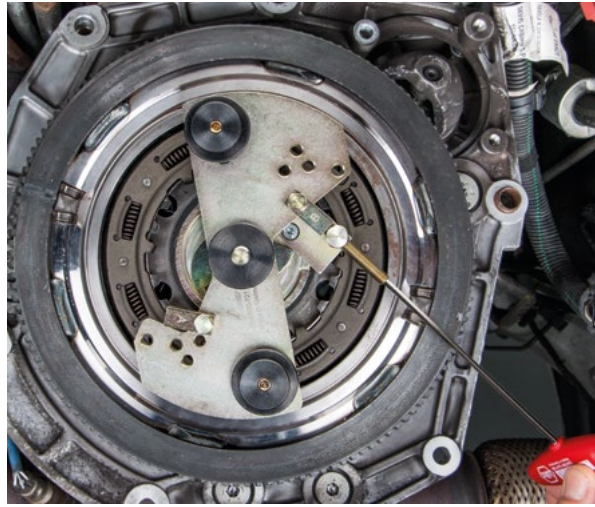

- Stop the procedure as soon as a small space is visible between spring tab and stop



- Screw the locking screws into the threaded holes labelled number 1 until there is contact with the spring tabs

**Note:**

With DMF versions 2, 3 and 4, the locking screws must be inserted into the correspondingly numbered threaded bores.

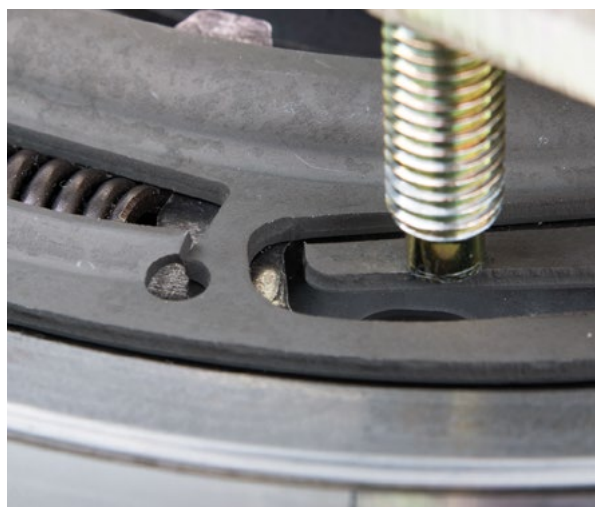

- Screw the locking screws in only until the spring tabs are level with the stops

**Important:**

The spring tabs can break off if the locking screws are screwed in too deep!

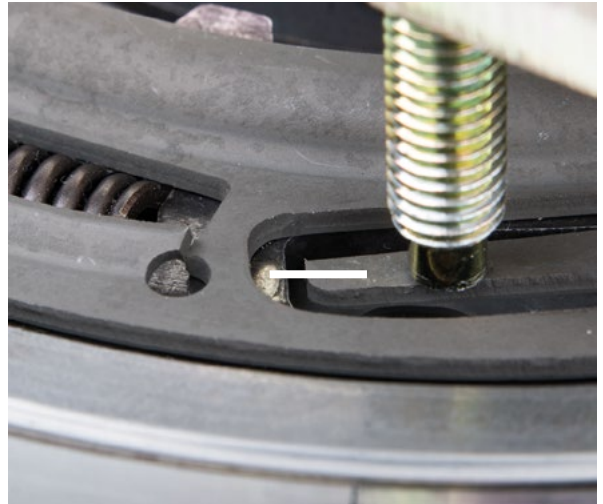

- Unscrew the reset screw so that both spring tabs touch the stops
- Remove the special tool
- Install the transmission according to the vehicle manufacturer's instructions

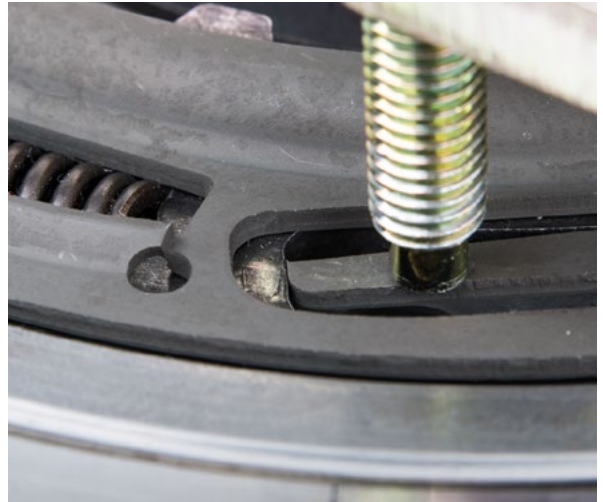

## 9 Installation and initial operation

- Install the transmission according to the vehicle manufacturer's instructions

### Important:

Engine and transmission must be brought together by hand so that both flanges are touching all round. Only then can the screws be fitted and secured with the prescribed tightening torque.

If the transmission cannot be moved into the installation position, the connection between the clutch and the DMF is tooth to tooth. In this case, the crankshaft can be turned slightly in the engine rotation direction until the gears engage.

If the transmission is forcibly pulled to the engine with the help of the bolts, the double clutch and the DMF will be damaged!

- Check the transmission oil level (specification according to the instructions of the vehicle manufacturer) and refill as necessary
- Check the hydraulic fluid level (specification according to the instructions of the vehicle manufacturer) in the transmission control and refill as necessary
- Before the first start, it is advisable to use a suitable diagnostic tool to check that the gearing of the clutch is correctly seated in the gearing of the DMF

### Workflow

- Connect the diagnostic tool and switch on the ignition
- Check the error memory. If error "P2949 – unwanted opening of the clutch for odd gears" is stored, the clutch is not properly seated in the teeth of the DMF – do not start the engine until the error has been eliminated
- Check the measured values. The indicators for the signals "Clutch position for odd gears" and "Position for closing clutch odd gears" must match. The value should be 10 ( $\pm 1.0$  mm). If a position value of under 7.8 mm is determined for the clutch for odd gears, this means that the clutch is not correctly seated in the teeth of the DMF. Do not start the engine until the error is eliminated



Bring the transmission as close as possible to the engine

### Final Work

- Perform a basic adjustment with a suitable diagnostic tool
- Carry out a test drive of at least 20 km
- Check the hydraulic fluid level in the transmission control again and if necessary add hydraulic fluid

### Note:

A complete adaptation of the clutch is performed within the first journey of 100 km. It is advisable to drive through all driving profiles (in town, country and on the motorway).

If there is still no satisfactory shifting comfort after this test route, the clutch characteristic line must be reconfigured using a suitable diagnostic tool.



# Notes

---

---

---

---

---

---

---

---

---

---

---

---

---

---

---

---

---

---

---

---

---

---

---

---

---



